

Technical Specifications

| | |
|--|--|
| Power Supply | 9...28VDC PELV or battery pack (not included) |
| Power Consumption (PELV Powered) | typ. 67mW, max. 133mW (when LEDs on) |
| Power Consumption (Battery Powered) | typ. 0.25mW, max. 100mW (when LEDs on) |
| Battery Lifetime | Approx. 2 years |
| Safety Rating | IP20 |
| Ambient Temperature (PELV Powered) | -20...70°C / -4...158°F |
| Ambient Temperature (Battery Powered) | -20...54°C / -4...129°F |
| Humidity | 95% r.H. (non-condensing) |
| Radio Frequency | 868MHz (SRD band Europe), 915MHz (ISM band Region 2) max. Power 3.16mW |
| Dimensions | 304x115x18mm / 12x4.53x0.71" (LxWxH) |
| Surface Material | Stone, wood, ceramic or glass – please note that this product will not work with conductive materials. |
| Surface Thickness | max. 30mm / 1 3/16" |

Connection

| | |
|-------------------------------------|--|
| Wire conductor cross-section | 0.25...0.8mm ² / AWG18...AWG23 |
| Exposed Wire Length | 5mm / 0.2" |
| Push-In-Technology | To make a connection, insert the wire; to remove the wire twist and pull at the same time. |

Information

Contains FCC ID: COR-ZWIR4512AC1
This device complies with part 15 of the FCC rules. Operation is subject to the following two conditions:
1. This device may not cause harmful interference.
2. This device must accept any interference received, including interference that may cause undesired operation.

LOXONE

LOXONE

Need Help?

loxone.com/support



Touch Surface Air

Loxone Electronics GmbH
Smart Home 1
4154 Kollerschlag
Austria

loxone.com



V300419

Part No: 100285

About the product

Installed underneath your non-conducting surface (note the max. surface thickness of 30mm), the Loxone Touch Surface gives you the possibility to control your smart home using the Loxone Switch Standard.

To prevent accidental use, there is an activation button. Upon touching this button, the five touch points of the switch are activated for 5 seconds, and the remaining time will be displayed through the activation indicator. If the activation function is not needed, the activation button can be reconfigured as necessary in Loxone Config.

Features

- Loxone Switch Standard
- Accidental operation protection
- LED activation indicator

Installation

Installation without activation indicators

If you would prefer not to install the light pipes or mark the surface at all you can use the provided decal to show the touch points.

Mount the Touch Surface to the underside of the surface. Once powered up, pair and configure the Touch Surface using Loxone Config.

Installation with activation indicators

Prepare the surface on which the Touch Surface is to be installed by drilling 5 holes for the LED indicator lights and marking the touch points (we strongly recommend that the holes are drilled by a professional to avoid damage to the surface).

The activation indicator lights need to be installed on the Touch Surface prior to mounting it.

Mount the Touch Surface to the underside of the surface. To seal the holes for the activation indicator lights, use a transparent epoxy resin. It is important to ensure that no dirt or grit is present in the holes or on the underside of the mounting surface prior to using the resin. When applying the resin ensure that no air bubbles are created.

Once powered up, pair and configure the Touch Surface using Loxone Config.

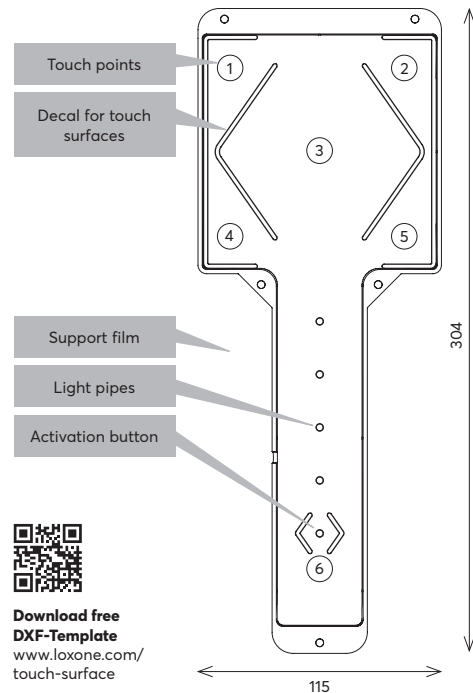
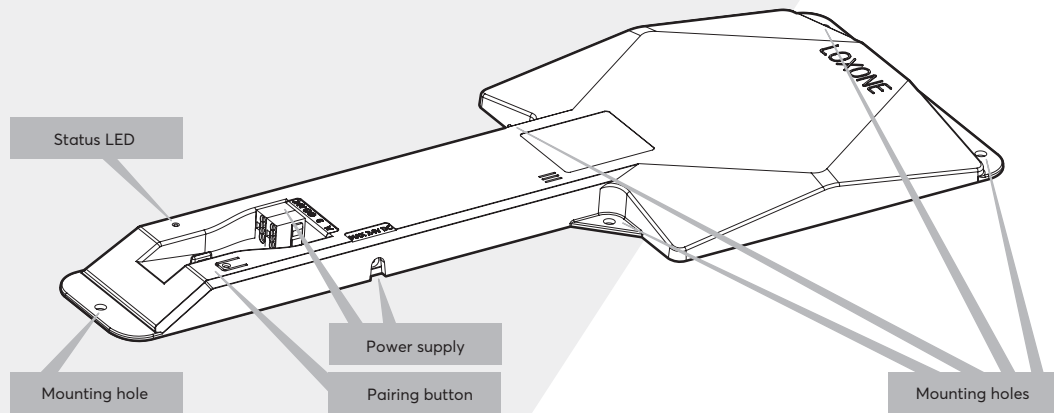

Download free
DXF-Template
[www.loxone.com/
touch-surface](http://www.loxone.com/touch-surface)



For additional information, declaration of conformity, visit www.loxone.com/help/touch-surface-air